

| REVISION HISTORY |  |                      |       |
|------------------|--|----------------------|-------|
| REV.             | DISCRIPTION                            | DATE                 | APP'D |
| A                | DRAWING ORIGINATION                    | 12/9/13              | AD    |
| B                | CORRECT BOTTOM/SIDE VIEW PIN COUNT ECN | 1732-05   08/07/2017 | jh    |

Top View

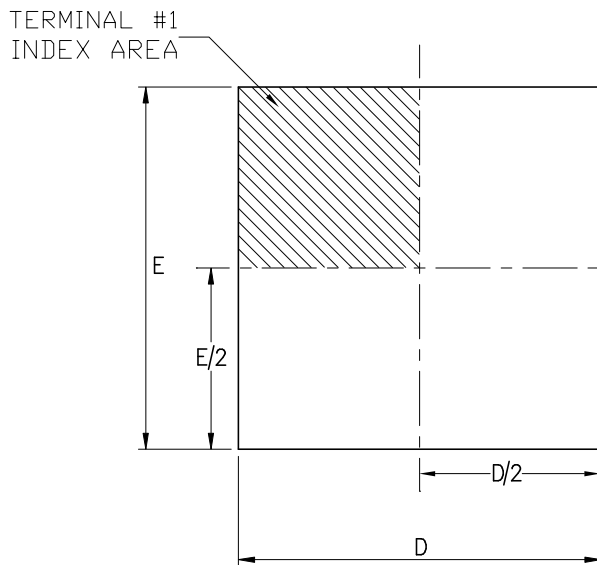

Bottom View

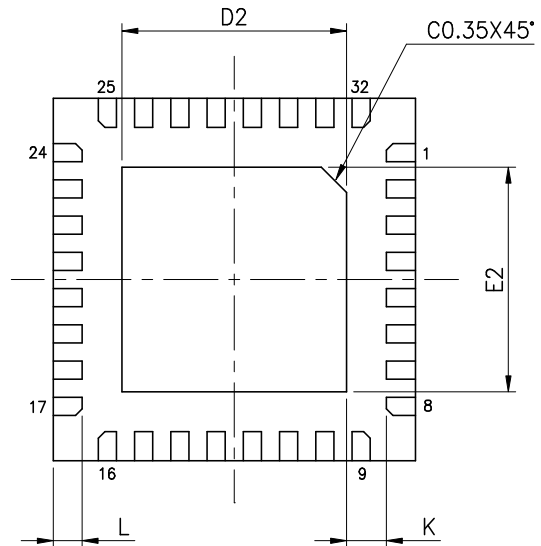

Side View

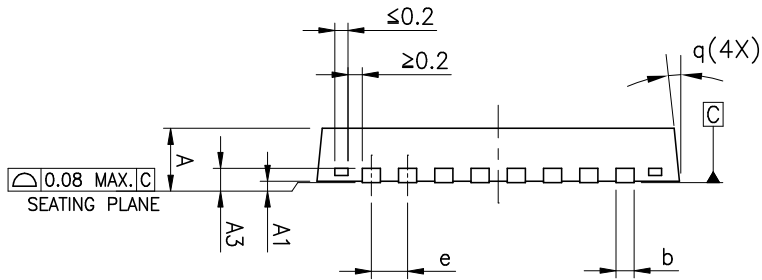

| 32LD 5x5 QFN (OPTION 3) JEDEC MO-220 Variation VHHD-4 |                                    |      |      |  |       |       |
|---|------------------------------------|------|------|--|-------|-------|
| SYMBOLS   | DIMENSIONS IN MM<br>(Control Unit) |      |      | DIMENSIONS IN INCH<br>(Reference Unit) |       |       |
|   | MIN                                | NOM  | MAX  | MIN                                    | NOM   | MAX   |
| A   | 0.80                               | 0.90 | 1.00 | 0.032                                  | 0.035 | 0.039 |
| A1  | 0.00                               | 0.02 | 0.05 | 0.000                                  | 0.001 | 0.002 |
| A3  | 0.20 REF                           |      |      | 0.008 REF                              |       |       |
| b   | 0.18                               | 0.25 | 0.30 | 0.007                                  | 0.010 | 0.012 |
| D   | 5.00 BSC                           |      |      | 0.197 BSC                              |       |       |
| D2  | 3.50                               | 3.65 | 3.80 | 0.138                                  | 0.144 | 0.150 |
| E   | 5.00 BSC                           |      |      | 0.197 BSC                              |       |       |
| E2  | 3.50                               | 3.65 | 3.80 | 0.138                                  | 0.144 | 0.150 |
| e   | 0.50 BSC                           |      |      | 0.020 BSC                              |       |       |
| L   | 0.35                               | 0.40 | 0.45 | 0.014                                  | 0.016 | 0.018 |
| K   | 0.20                               | —    | —    | 0.008                                  | —     | —     |
| q   | 0°                                 | —    | 14°  | 0°                                     | —     | 14°   |
| N   | 32                                 |      |      | 32                                     |       |       |
| ND  | 8                                  |      |      | 8                                      |       |       |
| NE  | 8                                  |      |      | 8                                      |       |       |

|                     |                                       |                             |
|---------------------|---------------------------------------|-----------------------------|
|                     | MAXLINEAR, INC.                       |                             |
|                     | 32 PIN 5X5 PACKAGE OUTLINE (OPTION 3) |                             |
| Packaging Approval: | Drawing No: POD-0000037               |                             |
| By: jh              | Date: 08/07/2017                      | Revision: B   Sheet: 1 of 2 |

| REVISION HISTORY |                                    |                          |       |
|------------------|------------------------------------|--------------------------|-------|
| REV.             | DISCRIPTION                        | DATE                     | APP'D |
| A                | DRAWING ORIGINATION                | 12/9/13                  | AD    |
| B                | CORRECT BOTTOM/SIDE VIEW PIN COUNT | ECN 1732-05   08/07/2017 | jh    |

RECOMMEND STENCIL DESIGN

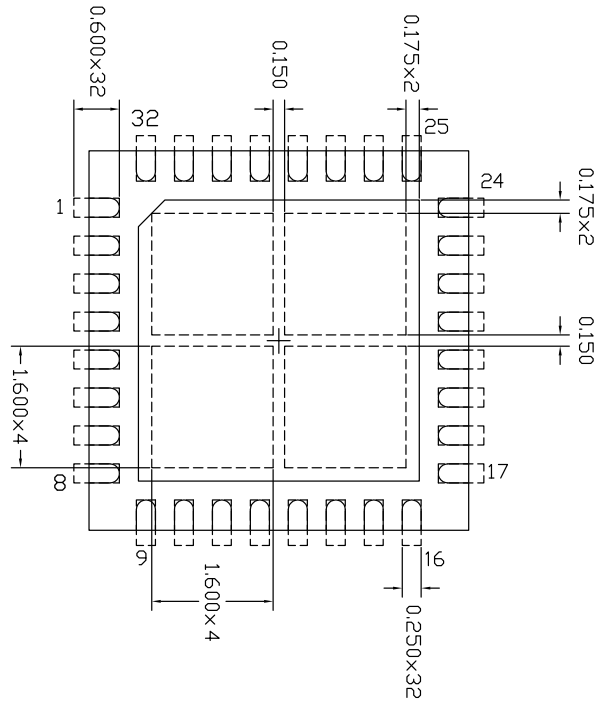

- DASH LINE REFERS TO SOLDER STENCIL OPENING

RECOMMEND LAND PATTERN

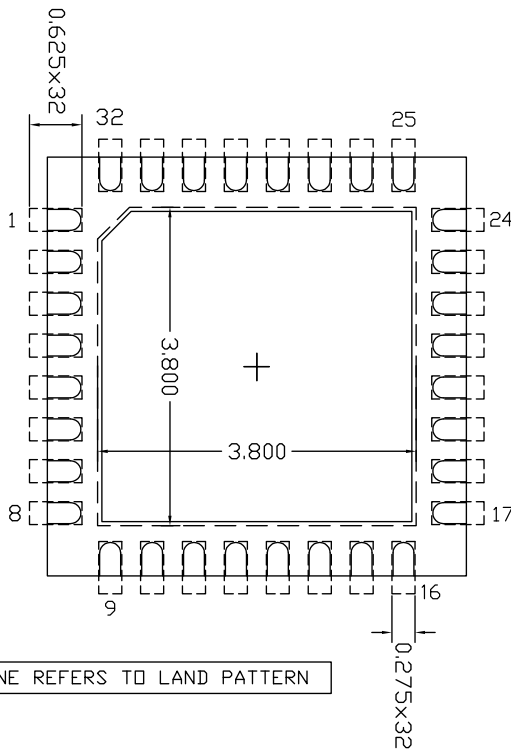

- DASH LINE REFERS TO LAND PATTERN

|  |                  |                                       |               |
|--|------------------|---------------------------------------|---------------|
|  |                  | MAXLINEAR, INC.                       |               |
|  |                  | 32 PIN 5X5 PACKAGE OUTLINE (OPTION 3) |               |
| Packaging Approval:  |                  | Drawing No: POD-0000037               |               |
| By: jh   | Date: 08/07/2017 | Revision: B                           | Sheet: 2 of 2 |