

REVISION HISTORY

REV.	DESCRIPTION	DATE	APP'D
C	CHANGE LAND PATTERN & STENCIL DWG TO MAKE IT BETTER TO UNDERSTAND	March/20/2018	ECN 1813-03 jh

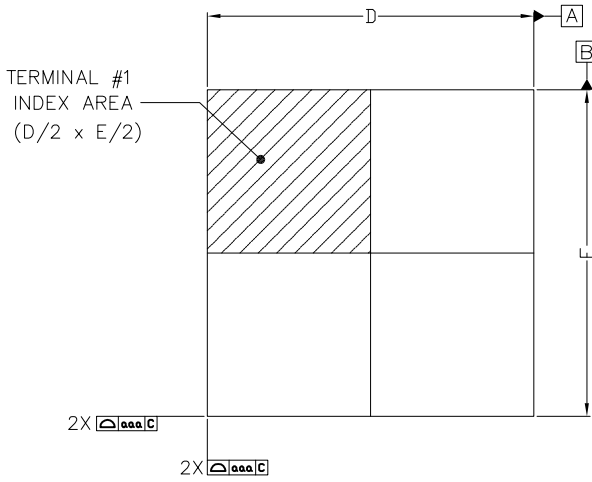

TOP VIEW

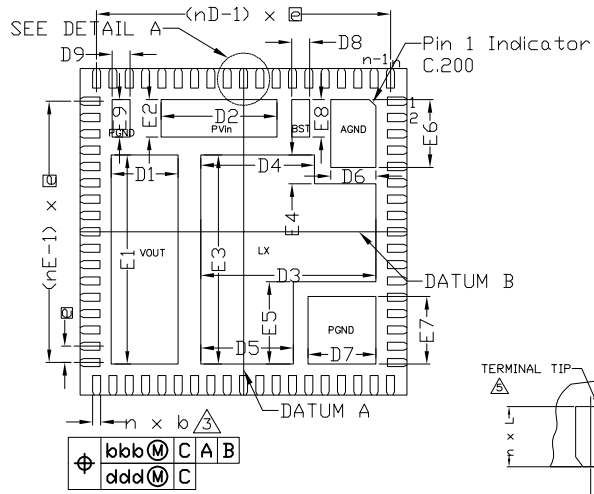

BOTTOM VIEW

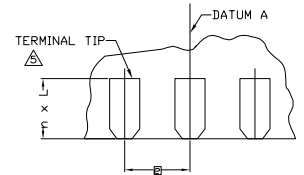

DETAIL A

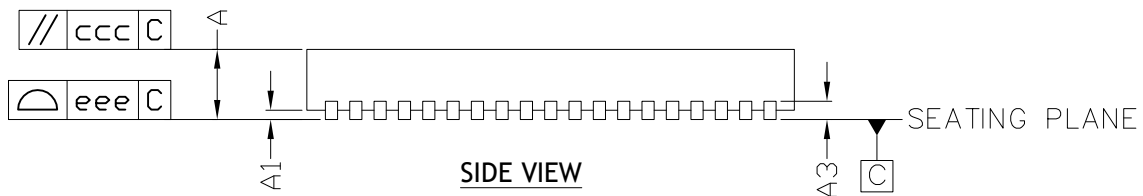

SIDE VIEW

PACKAGE 72L 10x10 QFN			
REF.	MIN.	NDM.	MAX.
A	3.90	4.00	4.10
b	0.20	0.25	0.30
L	0.50	0.60	0.70
D	10.00 BSC		
D1	1.94	2.04	2.14
D2	3.45	3.55	3.65
D3	5.26	5.36	5.46
D4	3.38	3.48	3.58
D5	2.735	2.835	2.935
D6	1.28	1.38	1.48
D7	1.975	2.075	2.175
D8	0.45	0.55	0.65
D9	0.45	0.55	0.65
E	10.00 BSC		
E1	6.30	6.40	6.50
E2	1.05	1.15	1.25
E3	6.30	6.40	6.50
E4	0.78	0.88	0.98
E5	2.425	2.525	2.625
E6	1.98	2.08	2.18
E7	1.975	2.075	2.175
E8	1.05	1.15	1.25
E9	1.05	1.15	1.25
e	0.50 BSC		
n	72		
nD	19		
nE	17		

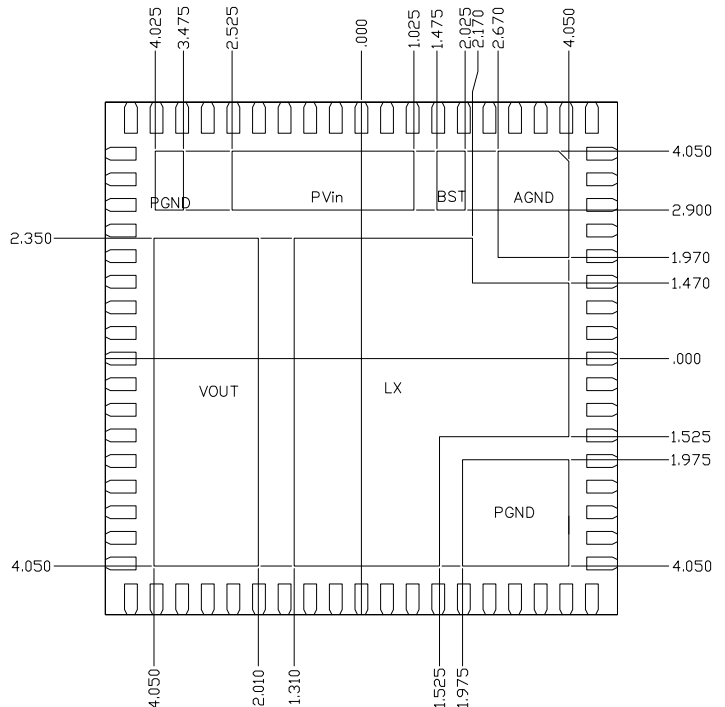

TERMINAL AND PAD EDGE DETAILS

NOTE : ALL DIMENSIONS ARE IN MILLIMETERS, ANGLES ARE IN DEGREES.

SYMBOL	COMMON DIMENSIONS			NOTE
	MIN.	NDM.	MAX.	
A1	0	0.02	0.05	
A3	0.20 REF.			
TOLERANCES OF FORM AND POSITION				
aaa	0.10			
bbb	0.10			
ccc	0.10			
ddd	0.05			
eee	0.08			

TERMINAL DETAILS

	MAXLINEAR CORPORATION	
	72LD 10x10x4.0mm QFN Package Outline Drawing	
Packaging Approval:	Drawing No.: POD-00000099	
By: YG Eom	Date: MAR.20.2018	Revision: C
		Sheet 1 OF 2

REVISION HISTORY

REV.	DESCRIPTION	DATE	APP'D
C	CHANGE LAND PATTERN & STENCIL DWG TO MAKE IT BETTER TO UNDERSTAND	March/20/2018	ECN 1813-03 jh

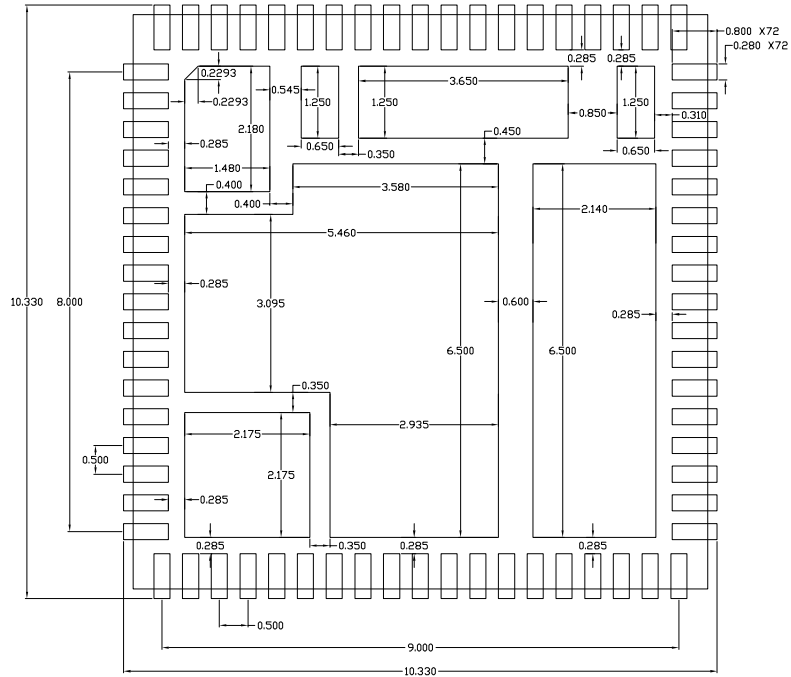

TYPICAL RECOMMENDED LAND PATTERN

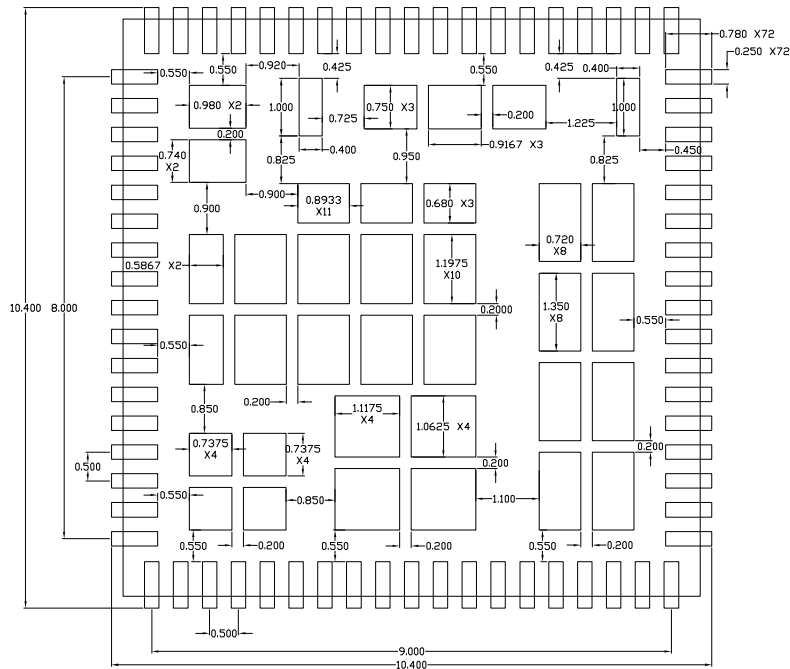

TYPICAL RECOMMENDED STENCIL

NOTE : ALL DIMENSIONS ARE IN MILLIMETERS, ANGLES ARE IN DEGREES.

	MAXLINEAR CORPORATION	
	72LD 10x10x4.0mm QFN Package Outline Drawing	
Packaging Approval:		Drawing No.: POD-0000099
By: YG Eom	Date: MAR.20.2018	Revision: C
Sheet 2 OF 2		