

REVISION HISTORY			
REV.	DISCRIPTION	DATE	APP'D
A	DRAWING ORIGINATION.	10/31/13	AD

TOP VIEW

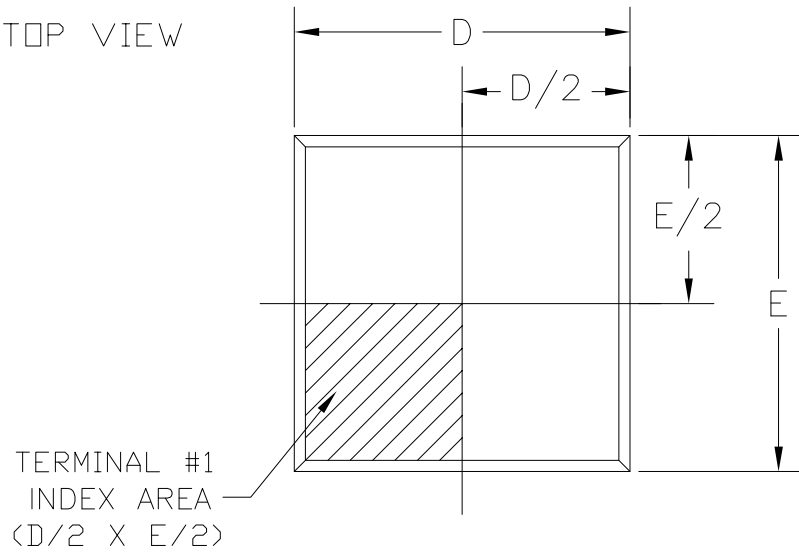

BOTTOM VIEW

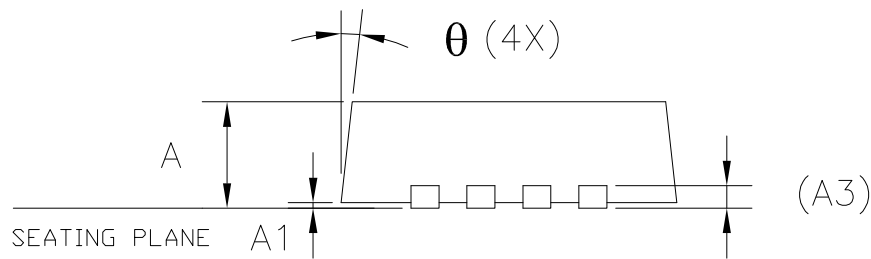
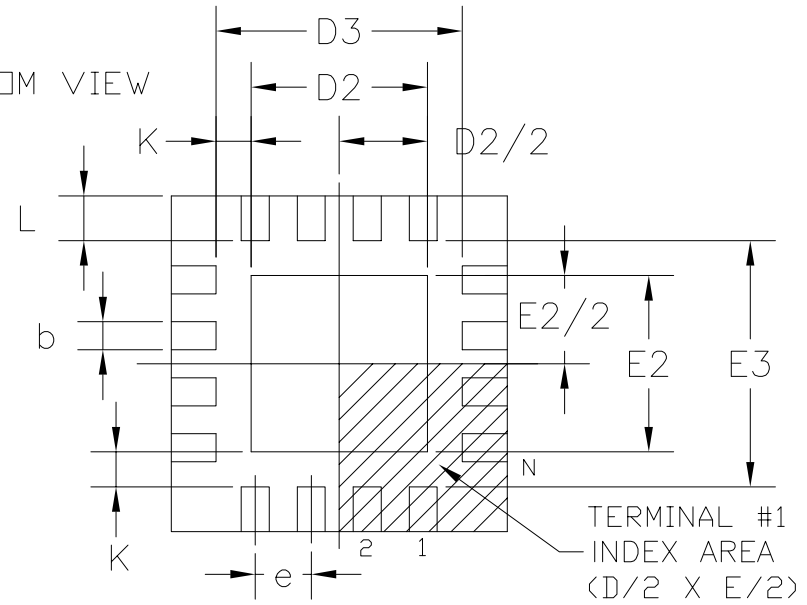

SIDE VIEW

		EXAR CORPORATION	
		TQFN PACKAGE OUTLINE	
Packaging Approval:		Drawing No: POD-00000009	
By: AD	Date: 10/31/13	Revision: A	Sheet: 1 OF 3



REVISION HISTORY

REV.	DISCRIPTION	DATE	APP'D
A	DRAWING ORIGINATION.	10/31/13	AD

48LD 7x7 TQFN JEDEC MO-220 Variation WKKD-4						
SYMBOLS	DIMENSIONS IN MM (Control Unit)			DIMENSIONS IN INCH (Reference Unit)		
	MIN	NOM	MAX	MIN	NOM	MAX
A	0.70	0.75	0.80	0.028	0.030	0.032
A1	0.00	0.02	0.05	0.000	0.001	0.002
A3	0.20 REF			0.008 REF		
b	0.18	0.25	0.30	0.007	0.010	0.012
D	7.00 BSC			0.276 BSC		
D2	5.00	5.10	5.20	0.197	0.201	0.205
E	7.00 BSC			0.276 BSC		
E2	5.00	5.10	5.20	0.197	0.201	0.205
e	0.50 BSC			0.020 BSC		
L	0.35	0.40	0.45	0.014	0.016	0.018
K	0.20	—	—	0.008	—	—
θ	0°	—	14°	0°	—	14°
N	48			48		
ND	12			12		
NE	12			12		

	EXAR CORPORATION		
	TQFN PACKAGE OUTLINE		
Packaging Approval:		Drawing No: POD-00000009	
By: AD	Date: 10/31/13	Revision: A	Sheet: 3 OF 3