

Revision History			
REV.	Description	Date	APP'D
B	Change lead qty from 49 to 56	March/04/2020	ECN 2011-02 jh

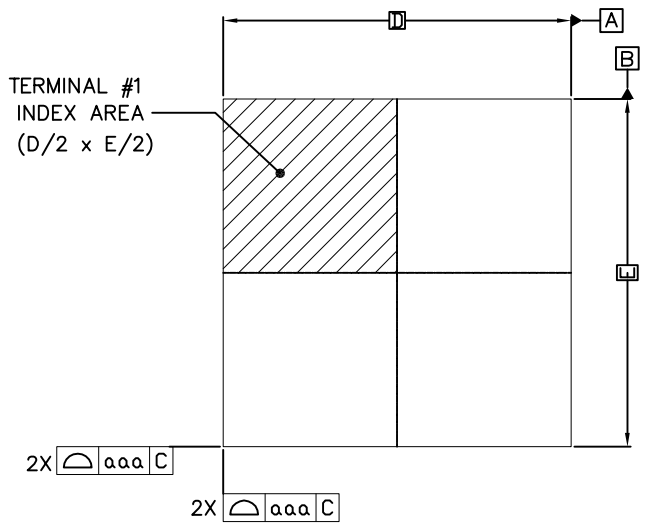

TOP VIEW

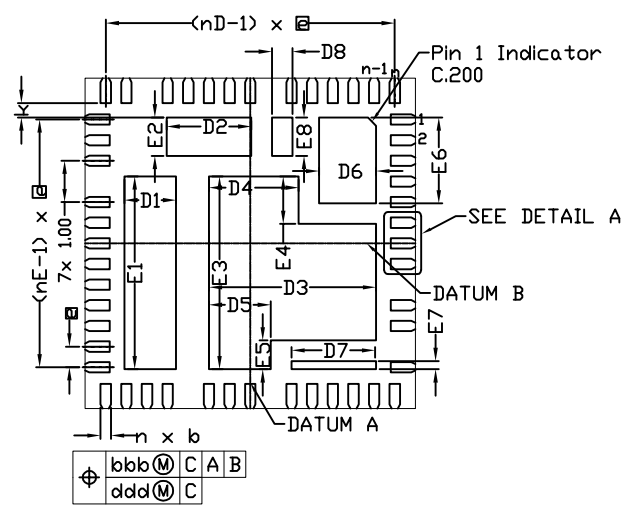

BOTTOM VIEW

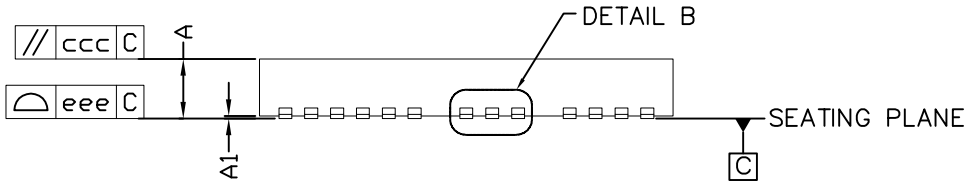

SIDE VIEW

PACKAGE	56L* 8x8 GQFNi-SIP		
REF.	MIN.	NOM.	MAX.
A	3.85	3.95	4.05
b	0.20	0.25	0.30
L	0.50	0.60	0.70
k	0.25	0.35	0.45
D	8.00 BSC		
D1	1.15	1.25	1.35
D2	1.95	2.05	2.15
D3	3.95	4.05	4.15
D4	2.07	2.17	2.27
D5	1.40	1.50	1.60
D6	1.28	1.38	1.48
D7	1.95	2.05	2.15
D8	0.40	0.50	0.60
E	8.00 BSC		
E1	4.57	4.67	4.77
E2	0.83	0.93	1.03
E3	4.57	4.67	4.77
E4	1.05	1.15	1.25
E5	0.60	0.70	0.80
E6	1.98	2.08	2.18
E7	0.10	0.20	0.30
E8	0.83	0.93	1.03
e	0.50 BSC		
n	56*		
nD	13		
nE	12		

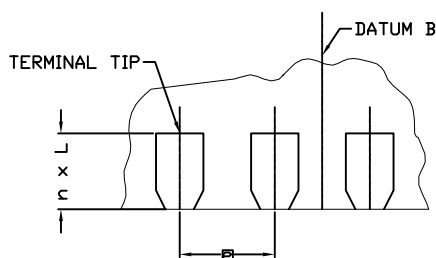

DETAIL A

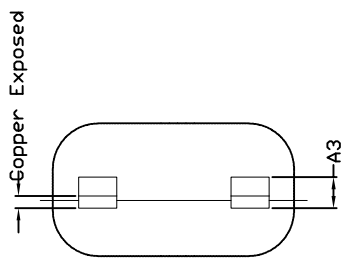

DETAIL B

SYMBOL	COMMON DIMENSIONS			NOTE
	MIN.	NOM.	MAX.	
A1	0.010	-	0.070	
A3	0.152 REF.			
TOLERANCES OF FORM AND POSITION				
aaa	0.10			
bbb	0.10			
ccc	0.10			
ddd	0.05			
eee	0.08			

TERMINAL DETAILS

NOTE : ALL DIMENSIONS ARE IN MILLIMETERS, ANGLES ARE IN DEGREES.
 * : ACTUAL LEAD COUNT IS 49, HOWEVER PIN NUMBERS RANGE FROM 1 TO 56.

		MAXLINEAR CORPORATION	
		56LD 8x8x4.05mm GQFNi Package Outline Drawing	
Packaging Approval:		Drawing No.: POD-00000155	
By: YG Eom	Date: March.04.2020	Revision: B	Sheet 1 OF 2

Revision History			
REV.	Description	Date	APP'D
B	Change lead q'ty from 49 to 56	March/04/2020	ECN 2011-02 jh

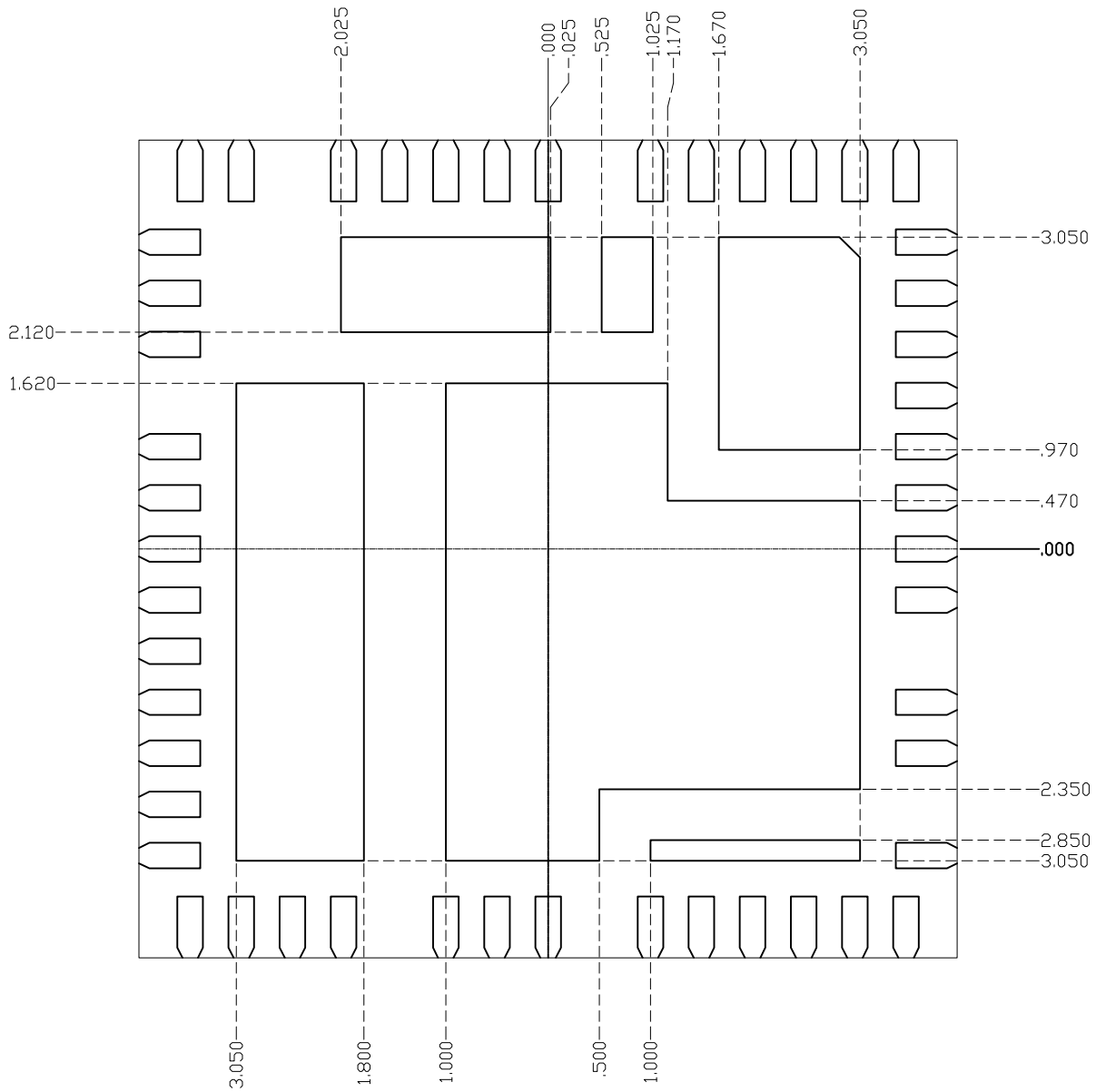

TERMINAL AND PAD EDGE DETAILS

NOTE : ALL DIMENSIONS ARE IN MILLIMETERS, ANGLES ARE IN DEGREES.

		MAXLINEAR CORPORATION	
		56LD 8x8x4.05mm GQFN Package Outline Drawing	
Packaging Approval:		Drawing No.: POD-00000155	
By: YG Eom	Date: March.04.2020	Revision: B	Sheet 2 OF 2