

REVISION HISTORY			
REV.	DISCRIPTION	DATE	APP'D
A	DRAWING ORIGINATION	11/09/09	PC
B	ADD UNITS (mm) TO DIMENSIONS	11/09/09	PC

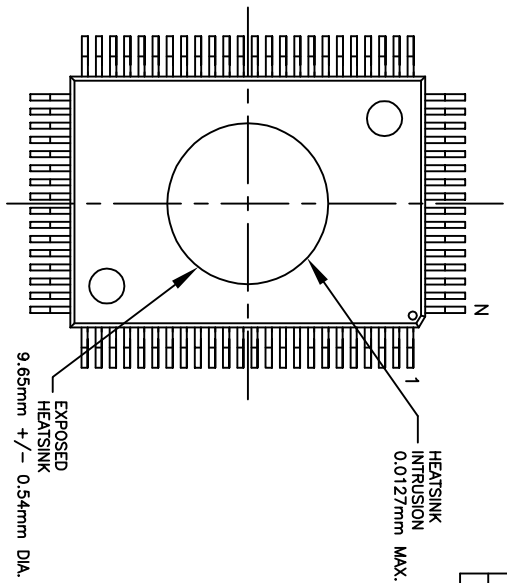

128 Pin 14X20 EDQUAD LQFP (THERMALLY ENHANCED)						
SYMBOLS	DIMENSIONS IN MM (Control Unit)			DIMENSIONS IN INCH (Reference Unit)		
	MIN	NOM	MAX	MIN	NOM	MAX
A	—	—	1.60	—	—	0.063
A1	0.05	0.10	0.15	0.002	0.004	0.006
A2	1.35	1.40	1.45	0.053	0.055	0.057
b	0.19	—	0.25	0.007	—	0.010
c	—	—	0.17	—	—	0.007
D	15.85	16.00	16.15	0.624	0.630	0.636
D1	13.95	14.00	14.05	0.549	0.551	0.553
E	21.85	22.00	22.15	0.860	0.866	0.872
E1	19.95	20.00	20.05	0.785	0.787	0.789
e	0.50 BSC			0.020 BSC		
L	0.50	0.60	0.75	0.020	0.024	0.030
L1	0.25 BSC			0.010 BSC		
θ	0°	3.5°	7°	0°	3.5°	7°
θ1	2°	6°	10°	0°	6°	10°
N	128			128		

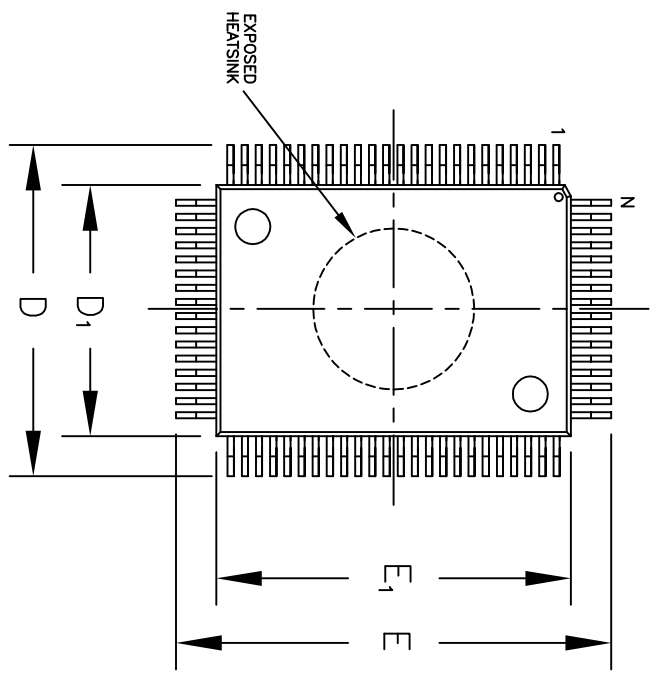
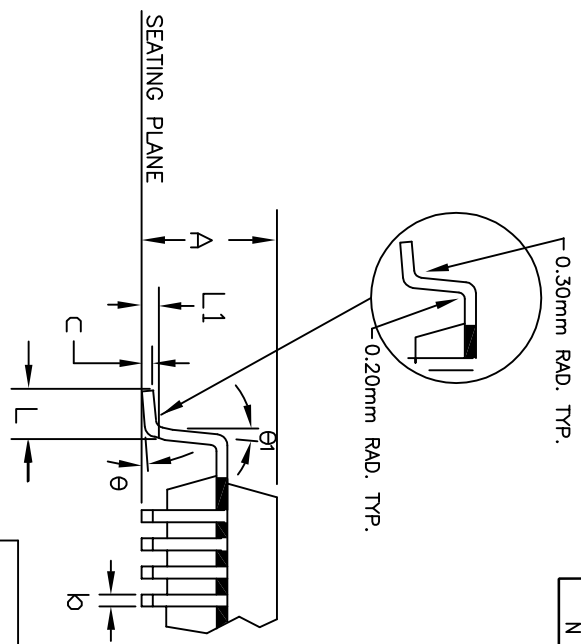

SIDE VIEW



EXAR CORPORATION

Packaging Approval:		128 PIN 14X20 EDQUAD LQFP PACKAGE OUTLINE	
By: PC	Date: 11/09/09	Drawing No: 128 PIN EDQUAD LQFP	Revision: B
Sheet: 1 OF 1			