

### Revision History

| REV. | Description        | Date          | APP'D                                       |
|------|--------------------|---------------|---|
| C    | UPDATE STENCIL DWG | April/13/2023 | ECN 2317-04 jh<br><small>04/26/2023</small> |

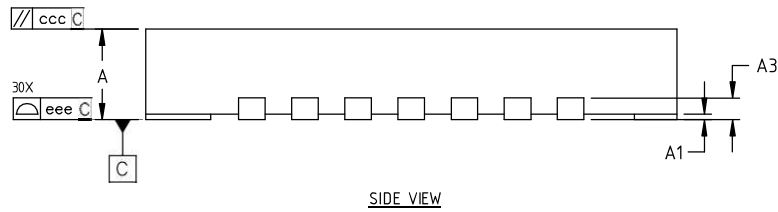
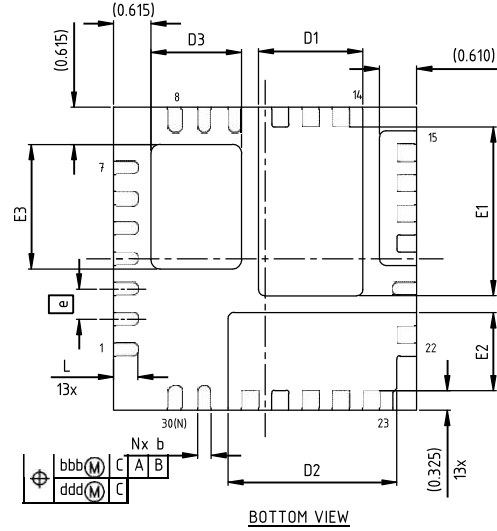
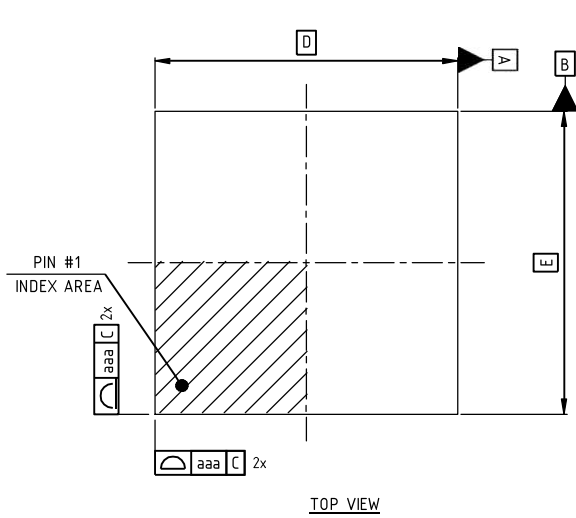

| Dimension Table  |           |         |         |
|------------------|-----------|---------|---------|
| Thickness Symbol | MINIMUM   | NOMINAL | MAXIMUM |
| A                | 0.80      | 0.90    | 1.00    |
| A1               | 0.00      | 0.02    | 0.05    |
| A3               | 0.20 Ref. |         |         |
| b                | 0.18      | 0.25    | 0.30    |
| D                | 5.00 BSC  |         |         |
| E                | 5.00 BSC  |         |         |
| e                | 0.50 BSC  |         |         |
| D1               | 1.570     | 1.720   | 1.820   |
| E1               | 2.635     | 2.785   | 2.885   |
| D2               | 2.635     | 2.785   | 2.885   |
| E2               | 1.135     | 1.285   | 1.385   |
| D3               | 1.345     | 1.495   | 1.595   |
| E3               | 1.903     | 2.053   | 2.153   |
| L                | 0.30      | 0.40    | 0.50    |
| aaa              | 0.05      |         |         |
| bbb              | 0.10      |         |         |
| ccc              | 0.10      |         |         |
| ddd              | 0.05      |         |         |
| eee              | 0.08      |         |         |
| N                | 30        |         |         |

TERMINAL DETAIL

NOTE : ALL DIMENSIONS ARE IN MILLIMETERS, ANGLES ARE IN DEGREES.

|                                      |  |              |
|--------------------------------------|--|--------------|
|                                      | <b>MAXLINEAR CORPORATION</b>               |              |
|                                      | 30LD 5x5x1.0mm QFN Package Outline Drawing |              |
| Packaging Approval:                  | Drawing No.: POD-00000018                  | Sheet 1 OF 2 |
| By: Onee R.      Date: April.13.2023 | Revision: C                                |              |

Revision History

| REV. | Description        | Date          | APP'D                                       |
|------|--------------------|---------------|---|
| C    | UPDATE STENCIL DWG | April/13/2023 | ECN 2317-04 jh<br><small>04/26/2023</small> |

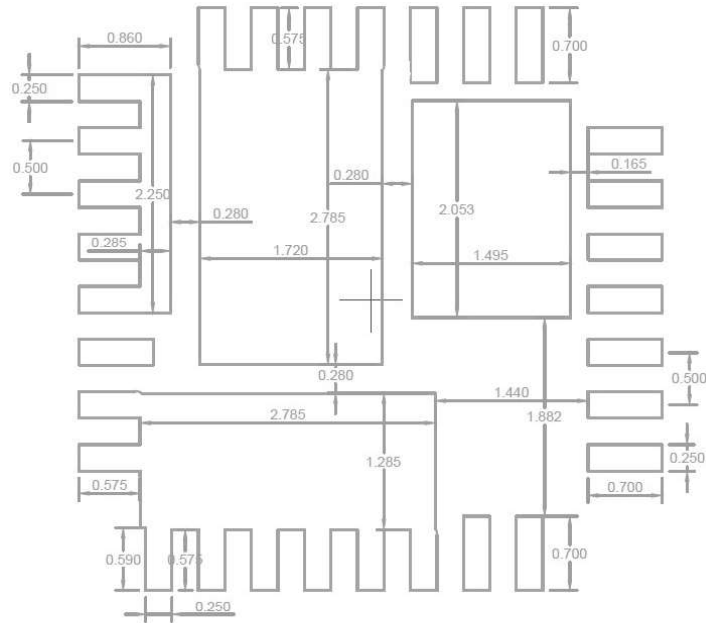

TYPICAL RECOMMENDED LAND PATTERN

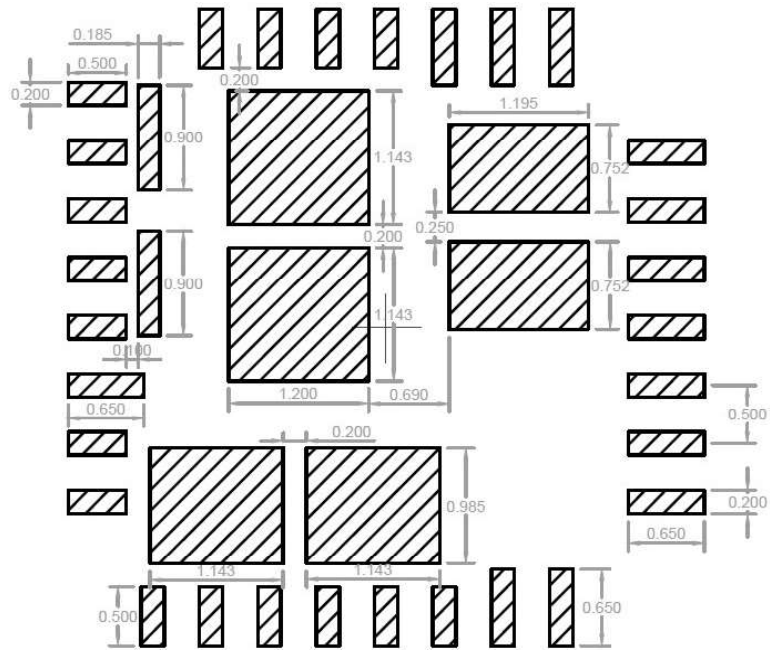

TYPICAL RECOMMENDED STENCIL

NOTE : ALL DIMENSIONS ARE IN MILLIMETERS, ANGLES ARE IN DEGREES.

|   |  |                           |              |
|---|--|---------------------------|--------------|
|  | <b>MAXLINEAR CORPORATION</b>               |                           |              |
|   | 30LD 5x5x1.0mm QFN Package Outline Drawing |                           |              |
| Packaging Approval:   |  | Drawing No.: POD-00000018 |              |
| By: Onee R.   | Date: April.13.2023                        | Revision: C               | Sheet 2 OF 2 |