

REVISION HISTORY			
REV.	DISCRIPTION	DATE	APP'D
A	DRAWING ORIGINATION	ECN 1721-05 05/22/2017	jh

Top View

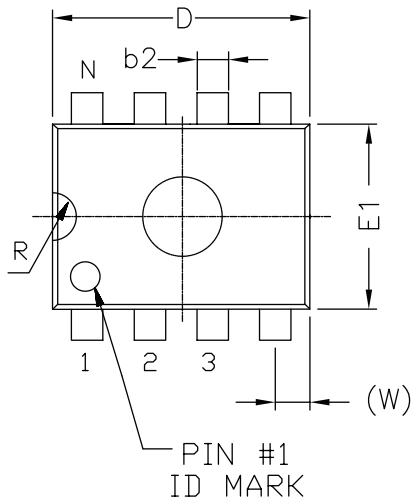

REMARKS:

ALL END LEADS (4X)
ARE HALF LEAD TYPES

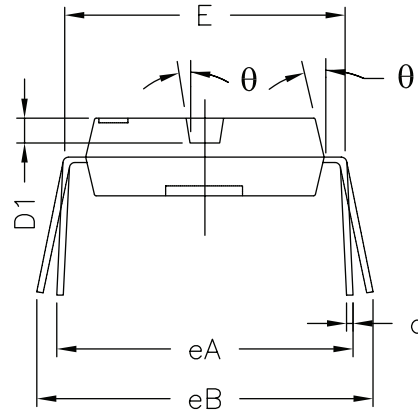
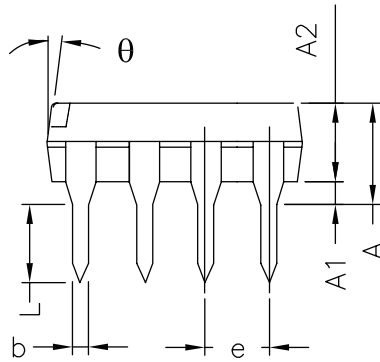
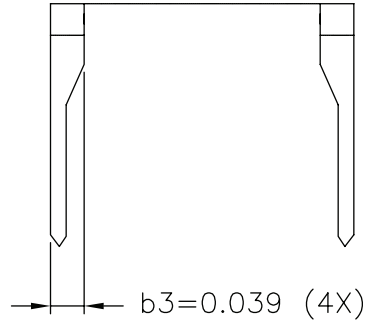

Side View

Front View

8 Pin PDIP JEDEC MS-001 Variation BA						
SYMBOLS	DIMENSIONS IN INCH (Control Unit)			DIMENSIONS IN MM (Reference Unit)		
	MIN	NOM	MAX	MIN	NOM	MAX
A	—	—	0.210	—	—	5.33
A1	0.015	—	—	0.38	—	—
A2	0.115	0.130	0.195	2.92	3.30	4.95
b	0.014	0.018	0.022	0.36	0.46	0.56
b2	0.045	0.060	0.070	1.14	1.52	1.78
c	0.008	0.010	0.014	0.20	0.25	0.36
D1	0.030	—	0.060	0.76	—	1.52
E	0.300	0.310	0.325	7.62	7.87	8.26
E1	0.240	0.250	0.280	6.10	6.35	7.11
e	0.100 BSC		2.54 BSC			
eA	0.300 BSC		7.62 BSC			
eB	—	—	0.430	—	—	10.92
L	0.115	0.130	0.150	2.92	3.30	3.81
W	0.075 REF		1.91 REF			
R	0.030 BSC		0.76 BSC			
θ	4°	7°	10°	4°	7°	10°
D	0.355	0.365	0.400	9.02	9.27	10.16
N	8		8			

	EXAR CORPORATION		
	PDIP8 PACKAGE OUTLINE		
Packaging Approval:		Drawing No: POD-00000111	
By: YG	Date: 05/22/2017	Revision: A	Sheet: 1 of 1